

FLOW CONTROL VALVE

FAF 7490

7490



Features

- No need for extra energy by running on pressure network
- Easy and zero adjustment to demanded pressure
- Easy maintenance
- Does not require maintenance in operation for a long time due to its corrosion resistant components.
- Has a long working life in operation since coating has been made with phosphorization and over-dried epoxy powder paint.
- Performs perfect modulation in variable flows and even too low flow rates close to zero.
- Has a wide range of application with use of different pilot valves.

Temperature

- -10 °C +80 °C

Working Principle

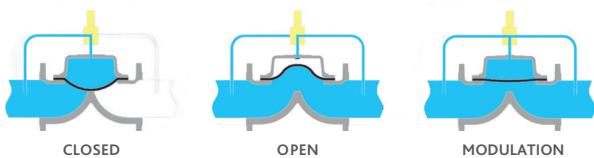

PRODUCTION STANDARTS

DN50 → DN300

Operation Pressure	0,7 - 16 bar (10 - 240 psi)
Connection	Flanged EN1092-2 Threaded ISO (BSP) - ANSI (NPT)
Corrosion Protection	Electrostatic Powder Epoxy

Product Description

FAF7490 Flow Control Valve is designed with the aim of controlling the flow in valve. it fixes the flow without being affected by surge pressure at valve inlet. it prevents waste of water by blocking over-flow in filtration systems during backwash.

Adjustment

- Connect the signal pipe and orifice plate sent together with the valve to the network as it is shown in user's manual. Move the three-way globe valve on the valve to automatic mode. Open the protection cap of the three-way pilot on the valve. If the flow passing through the valve is insufficient, boost the flow by screwing the adjusting bolt. If the flow passing through the valve is more than demanded amounts, reduce the flow by loosening the adjusting bolt.

Scope of Application

- Agricultural irrigation
- Supply of water fire extinguishing
- Various applications of industrial systems.
- Oil & gas applications
- Household implementation

Note

- For proper use and safety precautions please follow the installation and operating instructions.

FLOW CONTROL VALVE

FAF 7490

Model Application

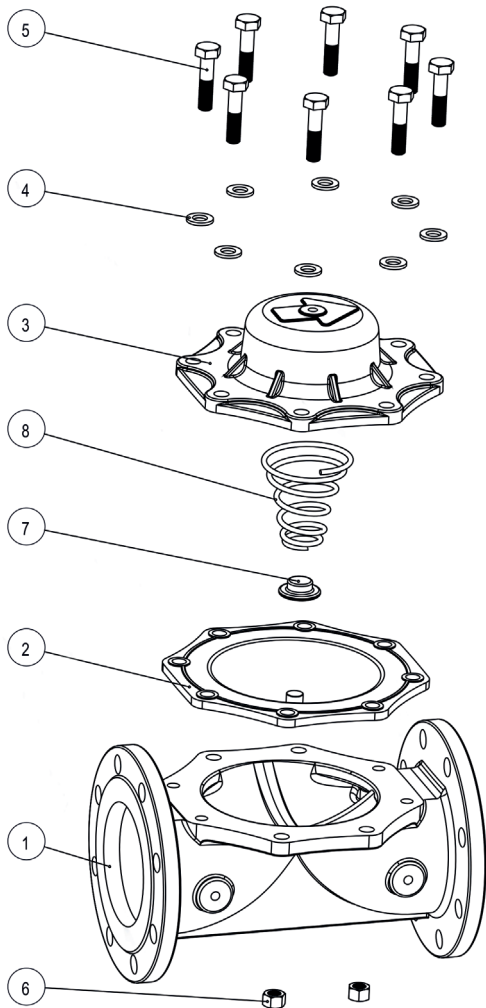
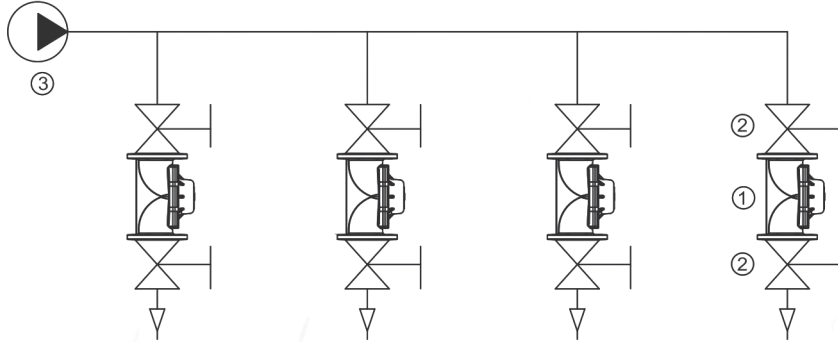

NO	PARTS
1	Flow Control Valve
2	Insulating Valve
3	Pump

CONTROL VALVES MODEL CODES	
FAF 7410	Pressure Reducing Control Valve
FAF 7420	Solenoid Controlled Pressure Reducing Control Valve
FAF 7430	Pressure Sustaining Control Valve
FAF 7440	Pressure Sustaining - Pressure Reducing Control Valve
FAF 7450	Pressure Relief Control Valve
FAF 7460	Float Level Control Valve
FAF 7470	Electric Float Level Control Valve
FAF 7480	Surge Anticipating Control Valve
FAF 7490	Flow Control Valve
FAF 7500	Horizontal Pump Control Valve
FAF 7510	Vertical Pump Control Valve
FAF 7520	Solenoid Control Valve
FAF 7530	Manual Control Valve

NO	ITEM	MATERIALS
1	BODY	EN-GJL-250 CAST IRON (GG25)
2	DIAPHRAM	COURT FABRIC-REINFORCED NATURAL RUBBER
3	COVER	EN-GJL-250 CAST IRON (GG25)
4	WASHER	PLATED STEEL
5	BOLT	PLATED STEEL
6	NUT	PLATED STEEL
7	SPRING THRUST RING	POLYAMID
8	SPRING	SST 302

VALVE TEST PRESSURE (Bar)		
MAX. OPERATING PRESSURE	BODY / SHELL TEST	SEAT TEST
16	24	17,6
100% of the valves are subjected to leakiness tests at FAF facilities.		

7490

FLOW CONTROL VALVE

FAF 7490

Dimensions And Weight

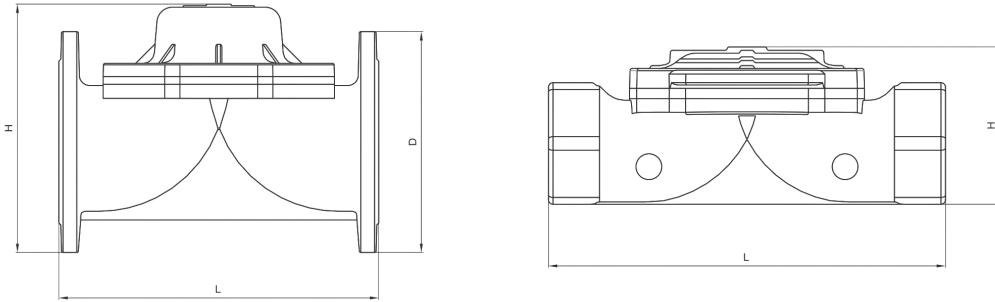

Flanged Valves

DN		L		D		H		WEIGHT	
inch	mm	inch	mm	inch	mm	inch	mm	lbs	kg
2"	50	8	204	6.4	165	6.4	165	33	15
2½"	65	8.1	206	7.2	185	7.2	185	36	16.5
3"	80	11.4	290	7.8	200	7.8	200	57	26
4"	100	11.6	296	8.6	220	8.6	220	61	28
5"	125	12.3	314	9.8	250	9.8	250	72	33
6"	150	16.2	413	11.2	285	12.6	321	125	57
8"	200	18.5	470	13.3	340	18.8	403	187	85
10"	250	18.5	470	16	407	17	433	226	103
12"	300	20.8	530	18.3	466	19.5	497	316	145

Threaded Valves

DN		L		H		WEIGHT	
inch	mm	inch	mm	inch	mm	lbs	kg
2"	50	8.1	206	4.2	107	28.6	13
2½"	65	9	230	4.3	110	30.8	14
3"	80	13.7	350	5.7	145	44	20

Suggested Operating Values

Operating Pressure	Standard	0,7 - 16 bar (10 - 240 psi)
Temperature	Minimum Operating Temperature	-10°C
	Maximum Operating Temperature	+80°C
Connection	Flanged	EN1092-2 ISO 7005-2
	Threaded	ISO (BSP) - ANSI (NPT)
Coating	Standard	Polyester
	Optional	Epoxy