

PRESSURE SUSTAINING CONTROL VALVES

FAF 7430

7430



PRODUCTION STANDARTS

DN50 → DN300

Operation Pressure	0,7 - 16 bar (10 - 240 psi)
Connection	Flanged EN1092-2 Threaded ISO (BSP) - ANSI (NPT)
Corrosion Protection	Electrostatic Powder Epoxy

Features

- No need for extra energy by running on pressure network.
- Classification according to the importance of pressure zones
- Selective loading of the line in sloping systems
- Manual switch on/off
- Control in different voltages No need tor extra energy by running on pressure network
- Does not require maintenance in operation for a long time due to its corrosion resistant components.
- Has a long working life in operation since coating has been made with phosphorization and over-dried epoxy powder paint.
- Performs perfect modulation in variable flows and even too low flow rates close to zero.
- Has a wide range of application with use of different pilot valves.

Temperature

- -10 °C +80 °C

Working Principle



Product Description

FAF7430 Pressure Sustaining Control Valves are designed to fix inlet pressure. When network pressure is over adjustment pressure, valve is opened and inlet pressure is fixed. It fixes the inlet pressure without being affected by surge pressure. Being installed at the end of the filter systems, the valve ensures productive back wash.

Adjustment

- If the value on manometer is below demanded pressure after giving water into the system, inlet pressure is made to increase by rotating adjusting bolt clockwise. If the value on manometer is above demanded pressure, demanded pressure is adjusted by rotating adjusting bolt counterclockwise. After this process, by screwing the lock nut under adjusting bolt, adjusting bolt is fixed.

Scope of Application

- Agricultural irrigation
- Supply of water fire extinguishing
- Various applications of industrial systems.
- Oil & gas applications
- Household implementation

Note

- For proper use and safety precautions please follow the installation and operating instructions.

PRESSURE SUSTAINING CONTROL VALVES

FAF 7430

Model Application

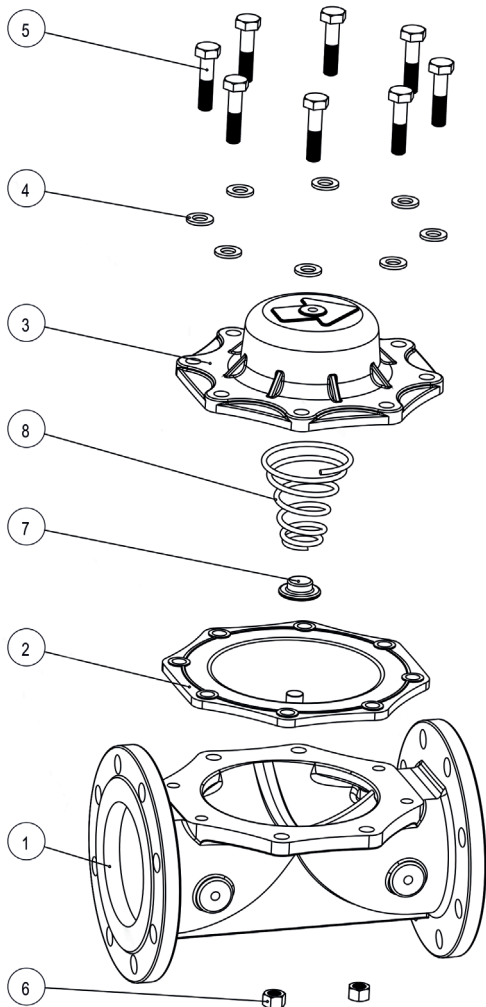
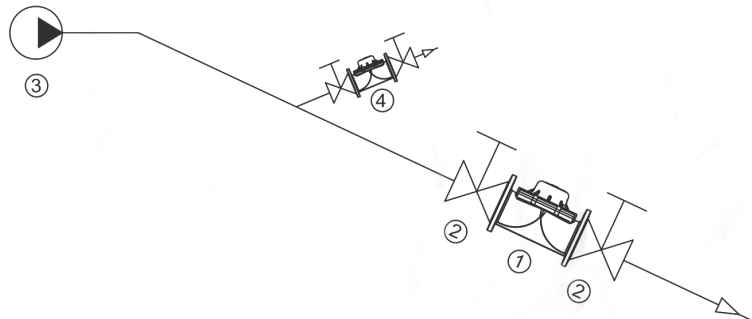
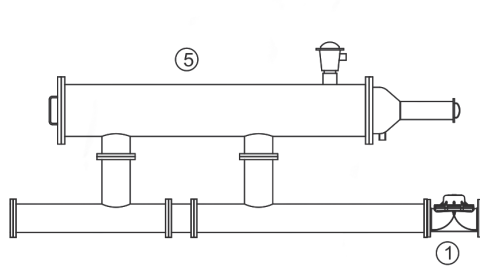

NO	PARTS
1	Pressure Sustaining Control Valve
2	Insulating Valve
3	Pump
4	Line Valve
5	Automatic Filter

CONTROL VALVES MODEL CODES

FAF 7410	Pressure Reducing Control Valve
FAF 7420	Solenoid Controlled Pressure Reducing Control Valve
FAF 7430	Pressure Sustaining Control Valve
FAF 7440	Pressure Sustaining - Pressure Reducing Control Valve
FAF 7450	Pressure Relief Control Valve
FAF 7460	Float Level Control Valve
FAF 7470	Electric Float Level Control Valve
FAF 7480	Surge Anticipating Control Valve
FAF 7490	Flow Control Valve
FAF 7500	Horizontal Pump Control Valve
FAF 7510	Vertical Pump Control Valve
FAF 7520	Solenoid Control Valve
FAF 7530	Manual Control Valve

NO	ITEM	MATERIALS
1	BODY	EN-GJL-250 CAST IRON (GG25)
2	DIAPHRAM	COURT FABRIC-REINFORCED NATURAL RUBBER
3	COVER	EN-GJL-250 CAST IRON (GG25)
4	WASHER	PLATED STEEL
5	BOLT	PLATED STEEL
6	NUT	PLATED STEEL
7	SPRING THRUST RING	POLYAMID
8	SPRING	SST 302

VALVE TEST PRESSURE (Bar)

MAX. OPERATING PRESSURE	BODY / SHELL TEST	SEAT TEST
16	24	17,6

100% of the valves are subjected to leakiness tests at FAF facilities.

7430



PRESSURE SUSTAINING CONTROL VALVES

FAF 7430

Dimensions And Weight

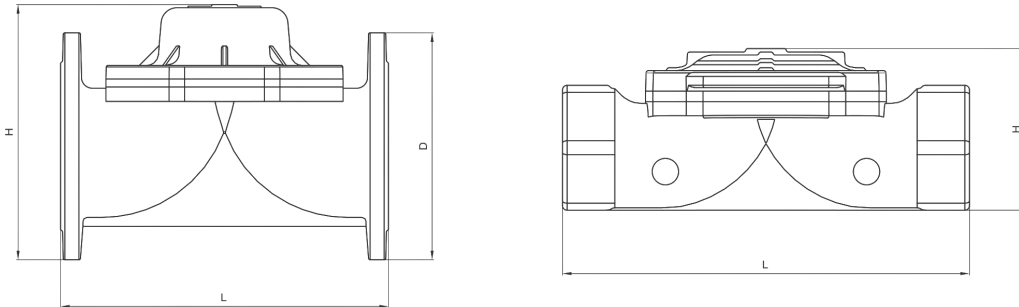

Flanged Valves

DN		L		D		H		WEIGHT	
inch	mm	inch	mm	inch	mm	inch	mm	lbs	kg
2"	50	8	204	6.4	165	6.4	165	33	15
2½"	65	8.1	206	7.2	185	7.2	185	36	16.5
3"	80	11.4	290	7.8	200	7.8	200	57	26
4"	100	11.6	296	8.6	220	8.6	220	61	28
5"	125	12.3	314	9.8	250	9.8	250	72	33
6"	150	16.2	413	11.2	285	12.6	321	125	57
8"	200	18.5	470	13.3	340	18.8	403	187	85
10"	250	18.5	470	16	407	17	433	226	103
12"	300	20.8	530	18.3	466	19.5	497	316	145

Threaded Valves

DN		L		H		WEIGHT	
inch	mm	inch	mm	inch	mm	lbs	kg
2"	50	8.1	206	4.2	107	28.6	13
2½"	65	9	230	4.3	110	30.8	14
3"	80	13.7	350	5.7	145	44	20

Suggested Operating Valves

Operating Pressure	Standard	0,7 - 16 bar (10 - 240 psi)
Temperature	Minimum Operating Temperature	-10°C
	Maximum Operating Temperature	+80°C
Connec tion	Flanged	EN1092-2 ISO 7005-2
	Threaded	ISO (BSP) - ANSI (NPT)
Coating	Standard	Polyester
	Optional	Epoxy