

BALL CHECK VALVE THREADED

FAF2295

2295



Features

- The ball rotates during operation eliminating the risk of impurities getting stuck on the ball.
- Can be installed in either vertical (upward flow only) or horizontal (cover upright) applications.
- Removable bonnet for cleaning or changing the ball without disassembly out of the pipeline.
- Smooth bore eliminates the risk of deposits at the bottom.
- Designed with focus on easy access to maintenance. By unscrewing a few bolts the bonnet assembly including hinge and ball can be removed from the body, and maintenance can be performed.
- All external surfaces are primed and painted for corrosion resistance.

Temperature

- -30 °C, +70 °C

PRODUCTION STANDARDS

DN40 → DN800
PN 10-16

Design	EN 12334
Connection	Threaded EN 228
Face to Face	EN 558 Series 48 / DIN 3202 F6
Marking	EN 19
Tests	EN 12266-1
Corrosion Protection	Electrostatic Bonded Epoxy

Product Description

FAF2295 Threaded Ball Check Valve is favorite and proven valve model in the submersible water and wastewater industry for decades. The valve is full bore thanks to the moving of the ball with self cleaning features.

Versions

- Standard version with NBR rubber vulcanised steel ball
- Custom production for specific orders

Scope of Application

- Non-potable water
- Sewage applications
- Wastewater treatment
- Neutral liquids
- Industrial applications

BALL CHECK VALVE THREADED FAF2295

2295

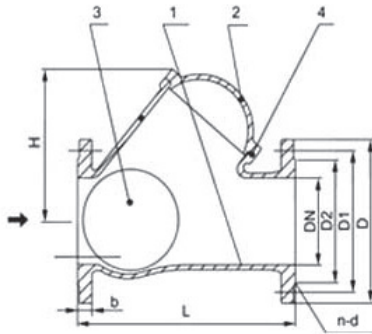

MATERIAL SELECTION

Body EN- GJS-400 Ductile Iron / GGG40

Bonnet EN- GJS-400 Ductile Iron / GGG40

Ball Steel + EPDM/NBR

Gasket EPDM/NBR

Bolting SS 304

PRODUCTS MODEL CODES

FAF2295	BALL CHECK VALVE THREADED
FAF2290	BALL CHECK VALVE

VALVE TEST PRESSURE (Bar)

MAX. OPERATING PRESSURE	BODY / SHELL TEST	SEAT TEST
10	15	11
16	24	17,6

100% of the valves are subjected to hydrostatic tests at FAF facilities.

Note

- For proper use and safety precautions please follow the installation and operating instructions.

NO	ITEM	MATERIALS
1	Body	Ductile Iron EN 655 400
2	Bonnet	Ductile Iron EN 655 400
3	Ball	Steel+NBR/EPDM
4	Bonnet Gasket	NBR/EPDM
5	Bolting	Stainless Steel AISI304

DN (mm)	NPS	L	D	D1	D2	n-Φd	b	h
50	2	200	165	125	102	4-18	19	100
65	2-1/2	240	185	145	122	4-18	19	125
80	3	260	200	160	138	8-18	19	136
100	4	300	220	180	158	8-18	19	185
125	5	350	250	210	188	8-18	19	196
150	6	400	285	240	212	8-22	19	265
200	8	500	340	295	268	8-22	20	340
250	12	600	405	350	320	12-22	22	420
300	14	700	460	400	370	12-22	24,5	480

